

NME1254 & FME1504 FOR THE INSTALLER

These machines are designed to fit the following Scotsman storage bins:

- SB480 and extensions (with bin top KBT18)
- HTB555 or BH550 - direct fit
- BH800 using bin top KBT23
- BH801 using bin top KBT29
- BH900 using bin top KBT22

NME1254 Dispenser Applications

The NME1254 can be placed on and used with certain ice and ice-beverage dispensers. Kits are required for proper operation.

- ID200 or ID250, use adapter KBT44 and KNUGDIV and KDIL-N-ID2
- Cornelius ED/DF200 beverage dispensers, use KBT44 and KDIL-N-200
- Cornelius ED/DF250 beverage dispensers, use KBT44 and KDIL-N-250
- Lancer special-for-nugget Ice Beverage Dispenser, use KDIL-N-L & Lancer kit #82-3491

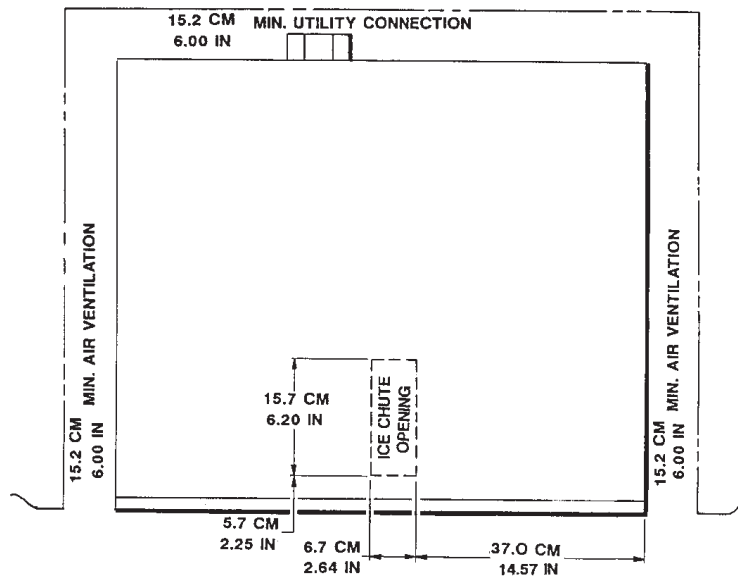
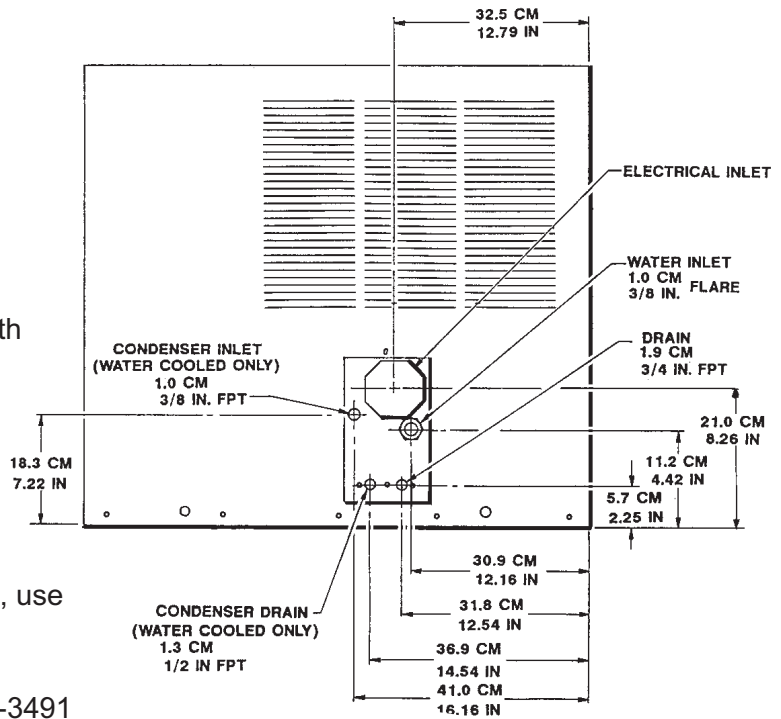

ICE MACHINE SPECIFICATIONS

Model Number	Cabinet Dimensions W" x D" x H"	Basic Electrical	Condenser Type	Ice Type	Refrigerant Charge (R-404A)	Minimum Circuit Ampacity	Maximum Fuse Size
FME1504AS-32B	30 x 24 x 27	208-230/60/1	Air Cooled	Flake	36 ounces	15.0	20
FME1504WS-32B	30 x 24 x 27	208-230/60/1	Water Cooled	Flake	24 ounces	14.3	20
NME1254AS-32B	30 x 24 x 27	208-230/60/1	Air Cooled	Nugget	36 ounces	15.0	20
NME1254WS-32B	30 x 24 x 27	208-230/60/1	Water Cooled	Nugget	24 ounces	14.3	20

Minimum circuit ampacity is used to determine wire size per National Electric Code.

FOR THE INSTALLER: Environmental Limitations

Installation Limitations:

This ice system is designed to be installed indoors, in a controlled environment:

	Min.	Max.
Air Temperature	50 ⁰ F	100 ⁰ F
Water Temperature	40 ⁰ F	100 ⁰ F
Water Pressure	20 psi	80 psi
Voltage	198	253

(Compared to the nameplate)

Operating the machine outside of the limitations is misuse and can void the warranty.

Water Limitations

An ice machine makes food. The purity of the water is very important in obtaining pure ice and in maximizing product life.

General Recommendations:

1. Filter the water used to produce ice (the water going to the potable water connection). Water filters vary in ability and function. Install one that filters out suspended solids to a dimension of 5 microns or smaller. The finer the filter the better, but finer filters will clog sooner than course ones. It may be necessary to add a course filter ahead of the fine filter to prolong filter life.
2. Check with a water treatment specialist for a water test, and recommendations regarding filters and treatment.

Scotsman Ice Systems are designed and manufactured with the highest regard for safety and performance. They meet or exceed the standards of UL, NSF, and CUL

Scotsman assumes no liability or responsibility of any kind for products manufactured by Scotsman that have been altered in any way, including the use of any part and/or other components not specifically approved by Scotsman.

Scotsman reserves the right to make design changes and/or improvements at any time. Specifications and design are subject to change without notice.

NME1254 & FME1504

FOR THE INSTALLER

Location

After uncrating and inspection, the unit is ready for installation. It is important that the machine be installed in a location where it has enough space around it to be accessible for service, and minimum of 6" be allowed to the left, right and top for air circulation on air cooled models. Try to avoid hot, dirty and crowded locations. Be sure that the location for the machine is within the limitations described on page 3.

Storage Bin

Tip the storage bin on its back, using parts of the carton to protect the exterior finish. Install the legs into the threaded holes in the bottom of the bin. Turn the leg levelers all the way in preparation for leveling later. Return the bin to the upright position, remove paper covering the bin gasket.

Install bin top if required.

Note: Do not push bin into position, instead lift it there. Pushing a bin, especially one with ice in it, can cause damage to the legs and the leg mounts.

Ice Machine

The machine is heavy, so the use of a mechanical lift is recommended for lifting the machine high enough to install on top of the bin. After the unit is placed on the bin, line it up so it is even with the back, left, and right sides. Secure the machine to the bin with the hardware provided with the machine.

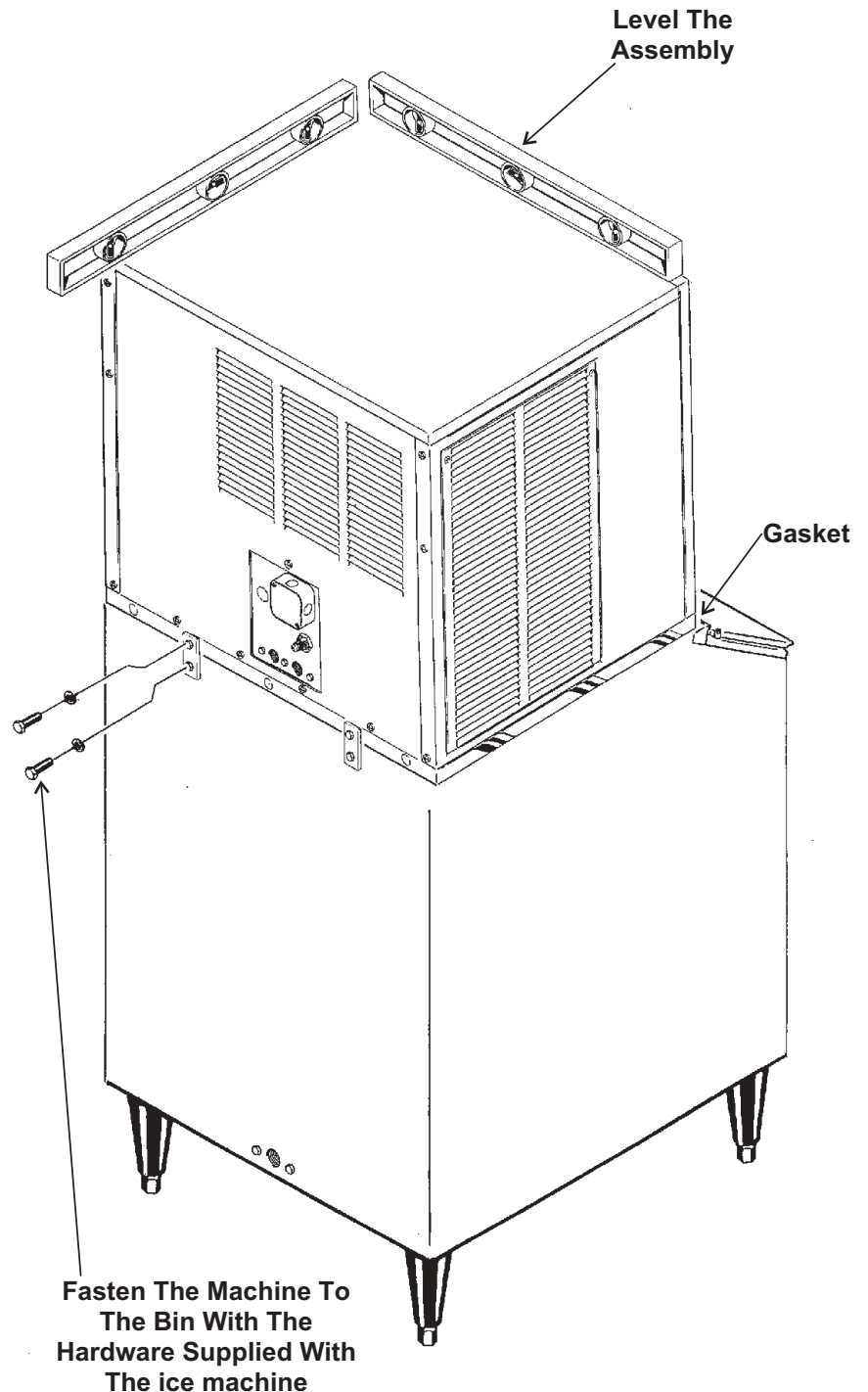

FOR THE PLUMBER

CONFORM TO ALL APPLICABLE CODES

Water Inlet

Air Cooled Models: Connect a water supply of cold, potable water. Use 3/8" O.D. copper tubing to connect to the 3/8" male flare at the back of the cabinet. Install a hand valve near the machine to control the water supply.

Air Cooled Models: Connect a drain tube to the 3/4" FPT drain fitting at the back of the cabinet. It is a gravity drain, and 1/4 inch per foot fall is an acceptable pitch for the drain tubing. There should be a vent at the highest point of the drain line, and the ideal drain receptacle would be a trapped and vented floor drain.

Water Cooled Models: In addition to the above
Use only 3/4" rigid tubing.

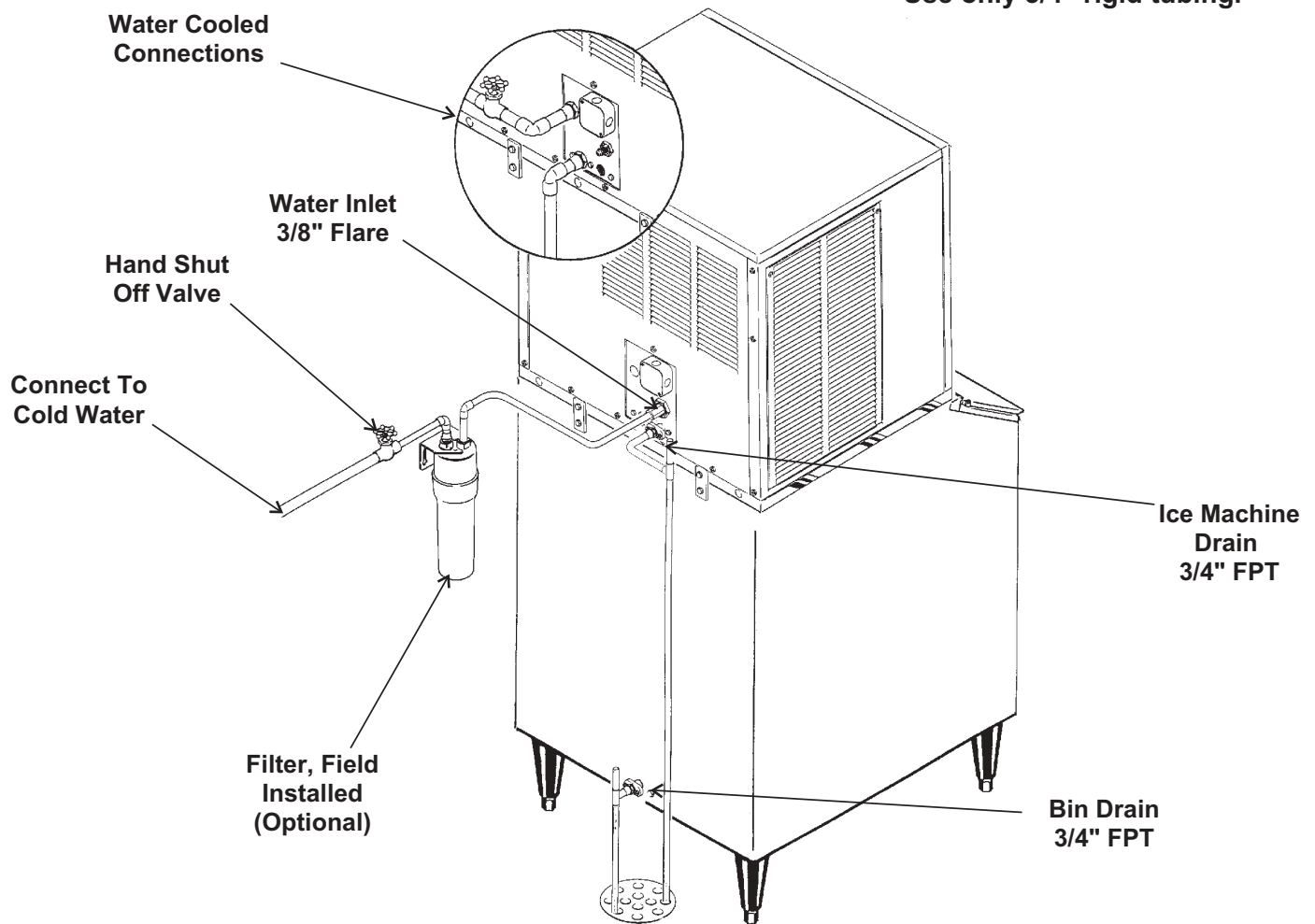

Water Cooled Models: Connect a separate 3/8" O.D. copper line with a separate hand valve to the 3/8" FPT condenser inlet at the back of the cabinet. The water pressure to all lines must always be above 20 psig, and below 80 psig.

mentioned drain, a separate condenser drain must be installed. Connect it to the 1/2" condenser drain connection at the back of the cabinet.

Storage Bin: A separate gravity type drain needs to be run, similar to the air cooled drain. Insulation of this drain line is recommended.

Drains

NME1254 & FME1504 FOR THE ELECTRICIAN

CONFORM TO ALL APPLICABLE CODES

Connect the electrical power to the power leads in the junction box at the rear of the machine.

Check the nameplate (located on the back panel) for the voltage requirements, and for the minimum circuit ampacity. The machine requires a solid chassis to earth ground wire.

Connect the ice machine to its own electrical circuit so it is individually fused.

Voltage variation must remain within design limitations, even under starting conditions.

All external wiring must conform to national, state, and local electrical codes. The use of a licensed electrician is required to perform the electrical installation.

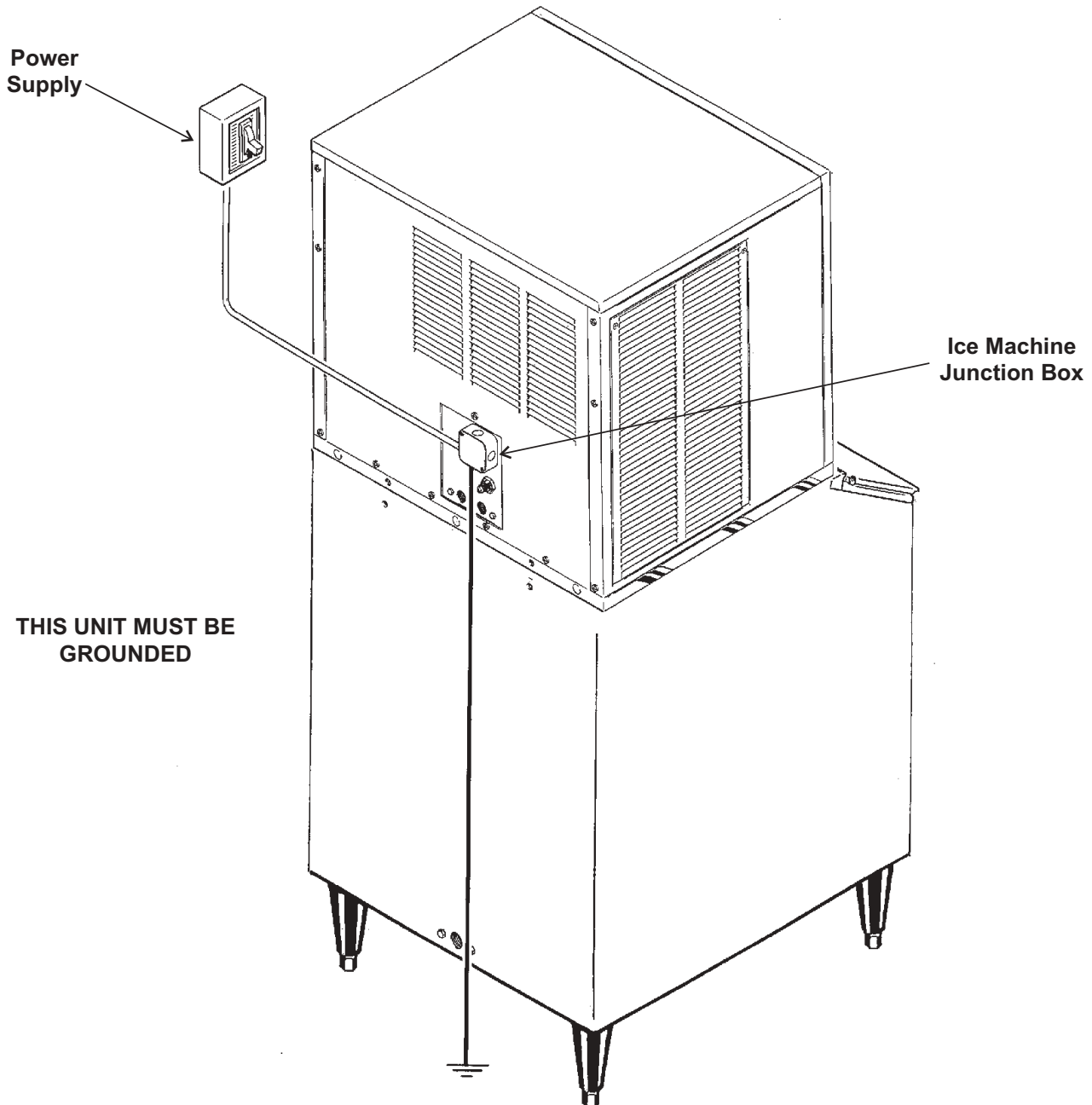

FOR THE INSTALLER: Final Check List

1. Is the ice system installed indoors in a location where the air and water temperatures are controlled, and where they do not exceed the design limitations?

2. Is there an electrical service disconnect within sight of the installed machine? Has the voltage been checked, and compared to nameplate requirements?

3. Have all the plumbing connections been made and checked for leaks?

4. Has the machine and bin been leveled?

5. Is there a minimum of 6" clearance at the rear, left, and right of the machine for proper service access and air circulation?

6. Is the water pressure a minimum of 20 psig?

7. Has the machine been secured to the bin?

8. Is there a water shut off valve installed near the machine?

9. Have the shipping blocks been removed from under the gearmotor, the top of the ice chute, and from between the gearmotor and the right side panel?

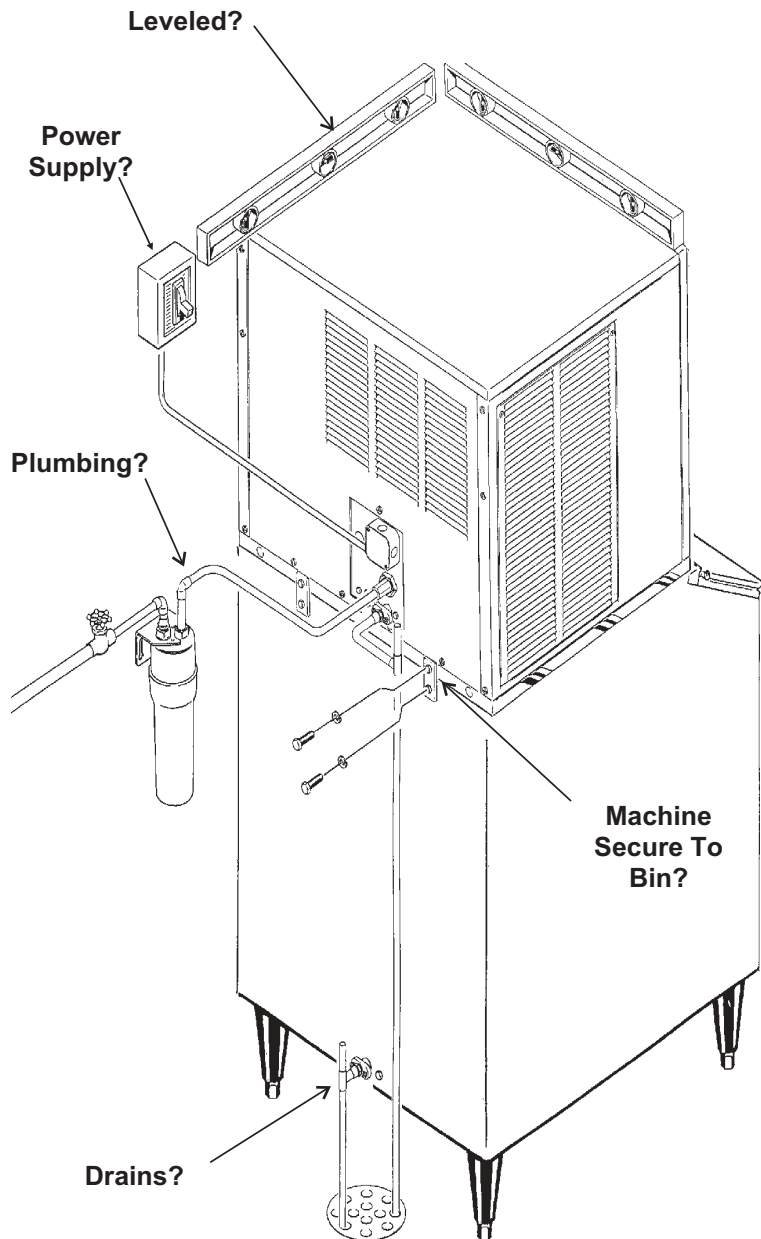

NME1254 & FME1504

START UP

Pre-Start Inspection

1. Remove the front, and left side service panels.
2. Check that the styrofoam shipping blocks under the gearmotor, on top of the ice discharge chute, and between the gearmotor and the right side panel have been removed.
3. Inspect the interior of the machine for loose screws or wires. Check that no refrigerant lines are rubbing each other. Check that the fan blade turns freely (air cooled).
4. Check that the unit is installed correctly according to the final check list (page 8).

Start Up

1. Go through the prestart inspection.
2. Open the hand valve, observe that water enters the water reservoir, fills the tube from the reservoir to the evaporator, and then shuts off. Check for leaks.
3. Switch the master switch on.
The electrical start up sequence is now on automatic.
 - A. There should be a short (15 second) delay before the gearmotor starts.
 - B. After the gearmotor starts, the compressor will start.
4. On air cooled models, the condenser will begin to discharge warm air, on water cooled models, the water regulating valve will open, and warm water will be discharged into the drain.

5. The unit should soon be making ice, if desired, the low side pressure can be checked: it should be between 30 and 32 psig. Low side pressure may be lower than 30 PSIG when the ambient is under 70°F. and higher than 32 when ambient is over 90°F.

The suction line temperature at the compressor is normally very cold, nearly to the point of frost up to the compressor body, but not on it.

The air cooled discharge pressure will depend upon air and water temperatures, but should be between 220 psig and 330 psig.

The water cooled discharge pressure should be constant at about 245 psig.

The above numbers are for new, clean machines, you can expect to see some values higher, and some lower between different units.

6. THERE ARE NO ADJUSTMENTS TO MAKE, so replace the panels.

7. Clean and/or sanitize the storage bin interior, wipe off the exterior with a clean, damp cloth.

8. Give the owner/user the service manual, instruct him/her in the operation of the unit, and make sure they know who to call for service.

9. Fill out the Customer Evaluation and Registration form, and mail it to Scotsman.

COMPONENT DESCRIPTION

Control Box: Contains the electrical controls that operate the machine.

Low Pressure Cut Out: An automatic reset switch set to shut the machine off should the low side pressure go below 15 PSIG.

High Pressure Cut Out: An automatic reset switch sensing the high side refrigeration pressure. It is set to shut the machine off at 450 PSIG.

Evaporator: A vertical stainless steel tube, refrigerated, and water filled. In it there is a stainless steel auger.

Reservoir: Float operated, it maintains the water level in the evaporator at a constant level, it also contains the water level sensor.

Water Level Sensor: Senses if there is water in the reservoir to make ice out of. Will shut the machine off if there is none.

Ice Discharge Chute: Directs the ice made by the evaporator into the storage bin.

Ice Level Sensor: An electronic "eye", it senses the presence of ice in the bottom of the ice discharge chute. Operates to turn the ice machine on and off automatically as the level of ice in the bin changes.

Gear Motor: An oil filled, speed reduction gearbox, driving the auger.

Cleaning Drain Tube: When uncapped and lowered, drains the evaporator.

Compressor: The refrigerant vapor pump.

Condenser: Air or water cooled, where the heat removed in ice making is discharged.

Expansion valve: The refrigerant metering device.

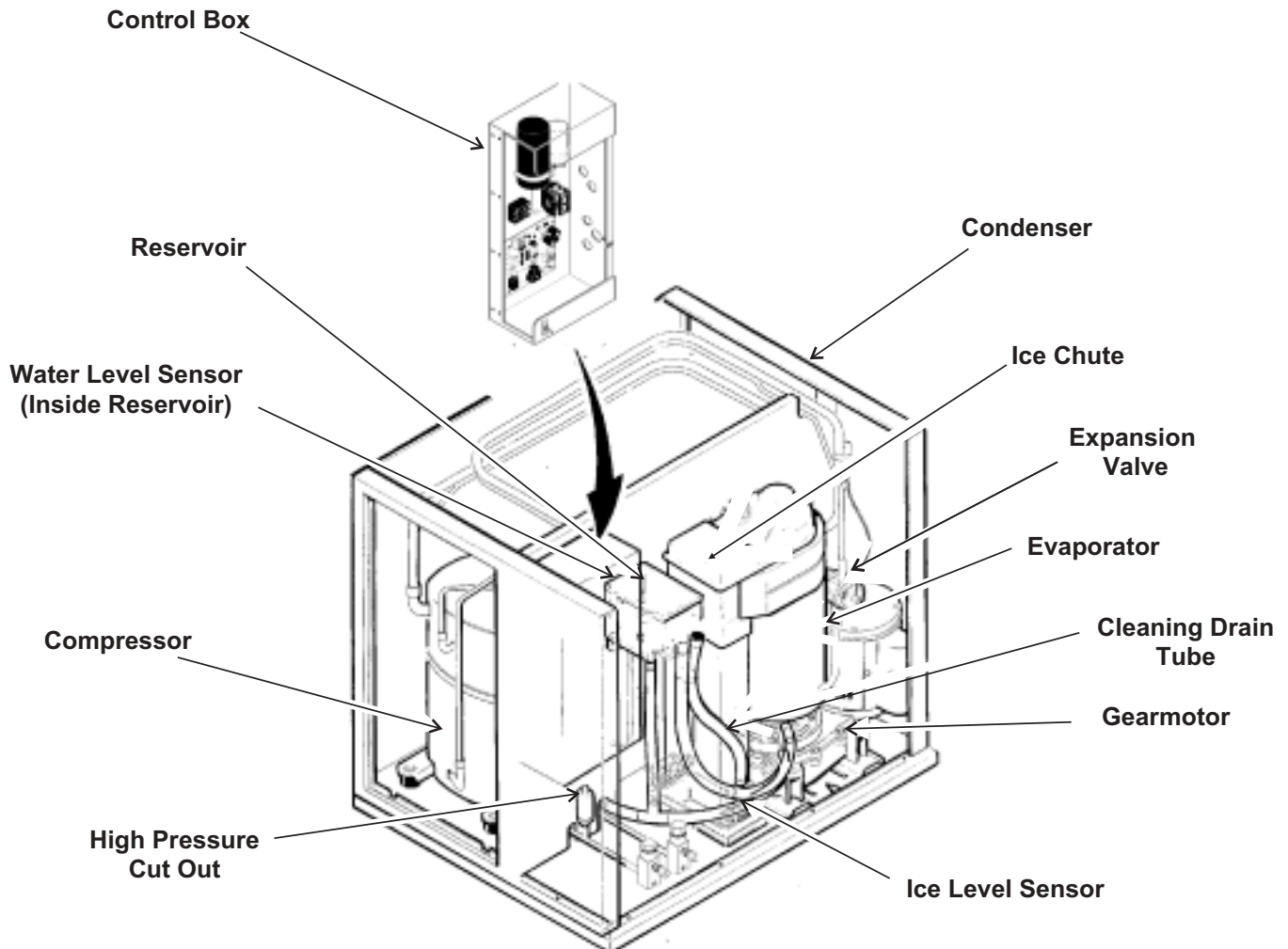

NME1254 & FME1504

Control Box

Contactor: A definite purpose contactor connecting the compressor to the power supply.

Circuit Board: Controlling the ice machine through sensors and relays. The sensors are for ice level and water level. The relays are for the gear motor (with a built in time delay to clear the evaporator of ice when the unit turns off) and for the compressor.

Potential Relay: The compressor start relay.

On/Off Switch: Manual control for the machine.

Control Board

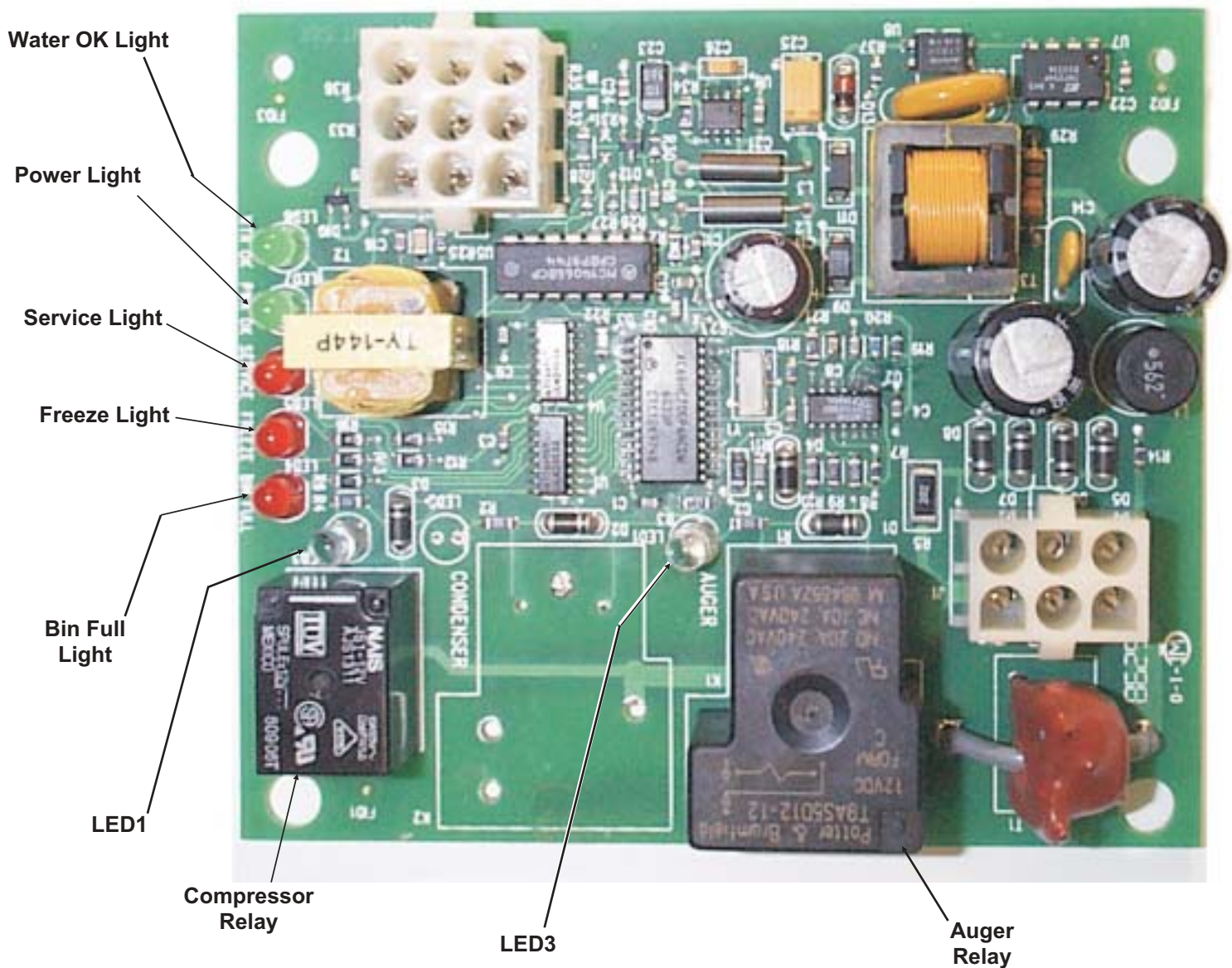

ELECTRICAL SEQUENCE:

There are 7 indicator lights on the control board:

- **WTR-OK** (Water OK). *Green*. **Normal = Glowing. Glows when there is water in the reservoir.**
- **PWR-OK** (Power OK). *Green*. **Normal = Glowing. Glows when the control board has power and is functional.**
- **Service**. *Red*. Normally Off.
- **Freeze**. *Red*. Normally glowing when making ice.
- **Bin Full**. *Red*. Normally Off when making ice.
- **LED1**. *White*. Located next to the board's Compressor Relay. Normally Glowing when making ice.
- **LED3**. *White*. Located next to the board's Auger Motor Relay. Normally Glowing when making ice.

If the machine is switched off at the mode switch, but is otherwise ready to go, switching the mode switch to ON does the following:

- The PWR-OK light glows.
- If there is water in the reservoir the WTR-OK light glows.
- After 10 seconds the Freeze, LED1 and LED3 lights glow and the machine starts up.

Start Up:

- The compressor relay and auger motor relay become energized, connecting power to the windings of the auger motor and contactor coil.
- The contactor is energized, connecting power to the compressor, and the compressor starts.
- As ice is made it passes between the ice level sensors but because it is not a continuous stream it only interrupts the sensor's infrared beam momentarily. The bin full light remains off and the machine stays on until ice builds up in the bin and blocks the path between the sensors for 6 seconds or longer. When that occurs the bin full light glows and the machine shuts down.

Shut Down:

- The compressor relay opens, LED1 goes out.
- The compressor contactor opens
- The compressor stops
- The auger motor stays on for 1 more minute, clearing out ice in the evaporator, and then
- The auger motor relay opens, LED3 goes out and the auger motor stops.

The compressor will not restart until 2 minutes or more have passed after the last shut down.

If the path between the ice level sensors remains clear for more than 10 seconds the ice machine will restart.

Control Board Protection Devices

- When the water level in the reservoir falls below the water level sensor's tip, the WTR-OK light goes out and the machine shuts down. When water refills the reservoir the WTR-OK light glows and the machine starts up again.
- If the auger drive motor current becomes excessive the compressor and auger drive motor will be switched Off and the Service light will blink. The control board will restart the auger drive motor in 4 minutes. If during the first 60 seconds after restart the auger motor current stays within limits, the compressor is restarted and the machine returns to normal operation. If the auger motor's current is excessive within 60 seconds after the restart, the process will be repeated once more. If during that try the current is still excessive the machine shuts down and must be manually reset. The service light will then be glowing continuously.

To Reset: Disconnect and reconnect power to the ice machine.

Other Protection Devices:

- If the **high pressure** cut out switch opens the machine will stop immediately. It will automatically reset when the pressure falls below its cut in point.
- If the **low pressure** cut out switch opens the machine will stop immediately. It will automatically reset when the pressure rises above its cut in point.

The **mode (on - off)** switch is the manual control for the complete machine, but it is not a service disconnect.

NME1254 & FME1504

COMPONENT DESCRIPTION

Evaporator: A refrigerated vertical tube filled with water and containing a water seal and auger.

Auger: A solid stainless steel double spiral auger, it pushes the ice crystals up to the top of the evaporator.

Water Seal: A two part "face" seal, the top half rotating with the auger, the bottom half stationary, the sealing action being where the two seal "faces" meet.

Ice Sweep: A plastic cap with "fingers". It revolves with the auger to "sweep" the ice into the ice chute.

Breaker: Where the ice is compressed and much of the extra water is squeezed out of it before it is discharged into the bin.

Motor: A split phase motor that drives the gear reducer.

Bearing: As the ice is pushed up the evaporator, the auger is thrust down, and pressure from the auger thrust is taken up by this bearing.

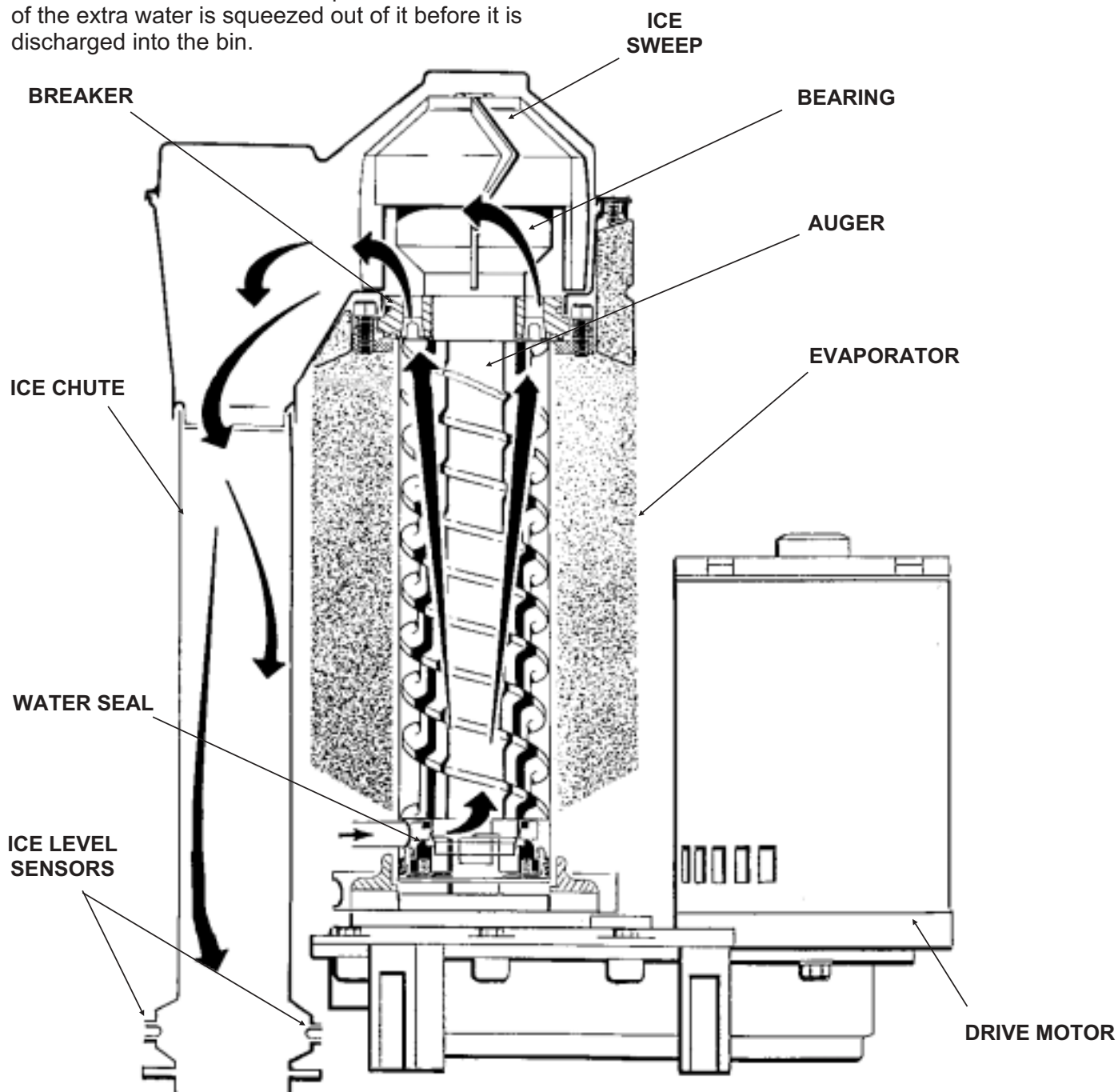

OPERATION

Water

Water enters the machine through the 3/8" male flare at the rear of the cabinet, goes to the water reservoir which it enters through the float valve.

The water then goes out the bottom of the reservoir tank to the bottom of the evaporator.

Reservoir overflow or evaporator condensation is routed to the drain.

Water cooled models have a separate water circuit for the cooling water: it enters the fitting at the rear, goes to the water regulating valve, then to the water cooled condenser and then down the drain.

Note: The water level may be checked by comparing the level of water in the reservoir to the line molded into the side of the reservoir. The water level should be between $\frac{1}{8}$ " above and $\frac{1}{4}$ " below the line. The water level may be adjusted by bending the arm of the float as needed.

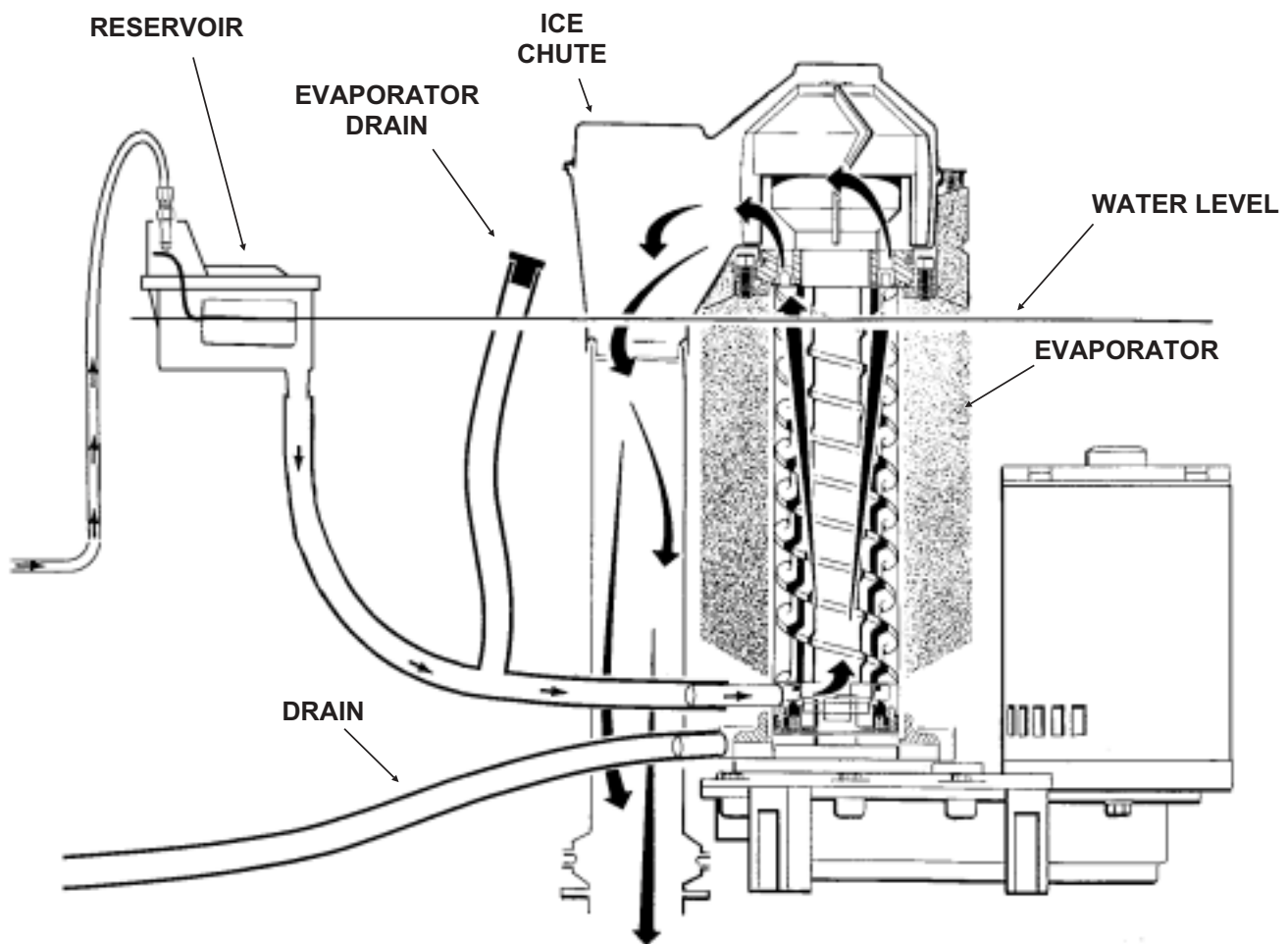

WATER SCHEMATIC

NME1254 & FME1504

OPERATION: Refrigeration

Beginning at the compressor, the refrigerant is compressed into a high temperature gas. The discharge line directs this gas to the condenser. At the condenser (air or water cooled) the gas is cooled by either air or water and it then condenses into a liquid. This high pressure liquid then goes through the liquid line to the expansion valve. The thermostatic expansion valve meters liquid refrigerant into the evaporator, the volume of liquid refrigerant depending upon the temperature of the evaporator; warmer evaporators get more refrigerant and colder evaporators get less.

At the evaporator, the refrigerant enters an area of relatively low pressure, where it can easily "boil off" or evaporate. As it evaporates, it absorbs heat from the evaporator and whatever is in contact with it (such as the water inside it). After the evaporator, the refrigerant, now a low pressure vapor, goes through the suction line back to compressor, where the cycle is repeated.

REFRIGERATION SYSTEM SCHEMATIC

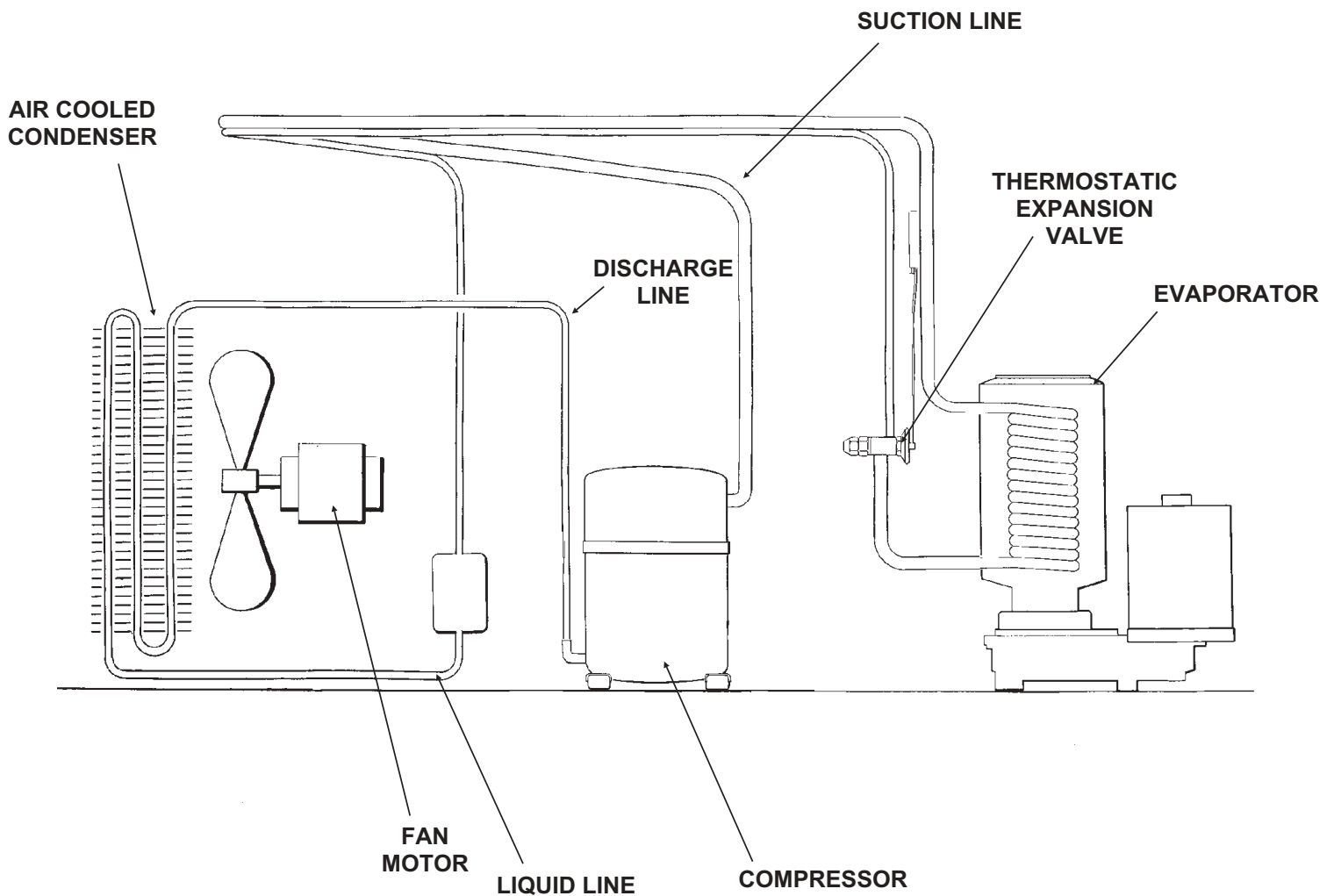

CLEANING & SANITIZING

A Scotsman Ice System represents a sizable investment of time and money in any company's business. In order to receive the best return for that investment, it **MUST** receive periodic maintenance.

It is the **USER'S RESPONSIBILITY** to see that the unit is properly maintained. It is always preferable, and less costly in the long run, to avoid possible down time by keeping it clean; adjusting it as needed; and by replacing worn parts before they can cause failure. The following is a list of recommended maintenance that will help keep the machine running with a minimum of problems.

Cleaning, Sanitation and other Maintenance should be scheduled at a **minimum of twice per year.**

Electrical power will be ON when doing in place cleaning.

ICEMAKING SYSTEM: In place cleaning

1. Check and clean any water treatment devices, if any are installed.
2. Pull out and remove the front panel.
3. Move the ON-OFF switch to OFF.
4. Remove all the ice from the storage bin.
5. Remove the cover to the water reservoir and block the float up.
6. Drain the water reservoir and freezer assembly using the drain tube attached to the freezer water inlet. Return the drain tube to its normal upright position and replace the end cap.
7. Prepare the cleaning solution: Mix eight ounces of Scotsman Ice Machine Scale Remover with three quarts of hot water. The water should be between 90-115 degrees F.

	<p>WARNING</p> <p>Scotsman Scale Remover contains acids. These compounds can cause burns.</p> <p>If swallowed, DO NOT induce vomiting. Give large amounts of water or milk. Call Physician immediately. In case of external contact, flush with water.</p> <p>KEEP OUT OF THE REACH OF CHILDREN.</p>
---	--

8. Slowly pour the cleaning solution into the water reservoir until it is full. Wait 15 minutes, then switch the master switch to ON.
9. As the ice machine begins to use water from the reservoir, continue to add more cleaning solution to maintain a full reservoir.
10. After all of the cleaning solution has been added to the reservoir, and the reservoir is nearly empty, switch the master switch to OFF.
11. After draining the reservoir, as in step 6, wash and rinse the water reservoir.

To Sanitize:

- Repeat steps 8-11, except use an approved sanitizing solution in place of the cleaning solution. A possible sanitizing solution may be made by mixing 1 ounce of household bleach to 2 gallons of warm (95°F. to 115°F.) water.
12. Remove the block from the float in the water reservoir.
 13. Switch the master switch to ON
 14. Continue ice making for at least 15 minutes, to flush out any cleaning solution.

DO NOT USE any ice produced from the cleaning solution.

Be sure no ice remains in the bin.

15. Remove all ice from the storage bin.
16. Add warm water to the ice storage bin and thoroughly wash and rinse all surfaces within the bin.
17. Sanitize the bin interior with an approved sanitizer using the directions for that sanitizer.
18. Replace the front panel.

NME1254 & FME1504

SENSOR and CONDENSER MAINTENANCE

1. The bin control is a device that senses light, and must be kept clean enough so that they can "see". At least twice a year, remove the bin control sensors from the base of the ice chute, and wipe the inside clean, as illustrated.

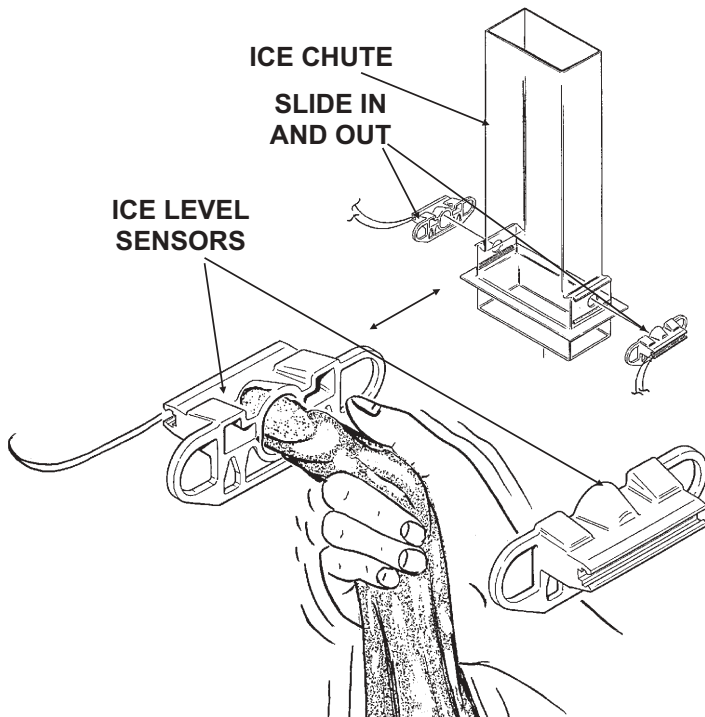

2. The ice machine senses water level by a probe located in the water reservoir. At least twice a year, the probe should be removed from the reservoir, and the tip wiped clean of mineral build-up.



Clean the Probe's Tip with ice machine cleaner and a clean, soft cloth.

3. Clean or replace the air cooled condenser filter. Clean the air cooled condenser. Use a vacuum cleaner or coil cleaner if needed. Do NOT use a wire brush.

BEARING MAINTENANCE

The bearing in the breaker should also be checked at least **two times per year**.

A. Check the bearing by:

- removing the ice chute cover



- unscrewing the ice sweep



- removing the water shed & unscrewing the breaker cover (left hand threads).

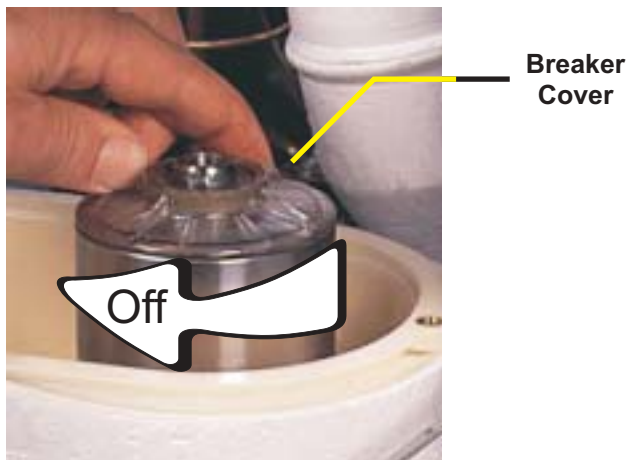

- unscrewing the auger stud

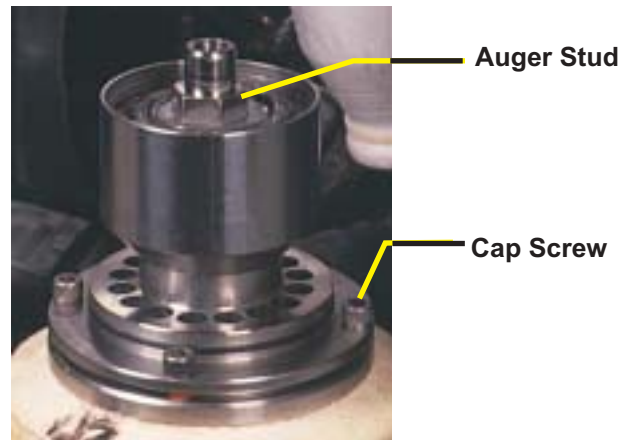

Inspect the bearing. There should be plenty of grease in sight. If grease is needed the bearing and breaker should be removed to check the action of the bearing. It should rotate smoothly. To remove the breaker remove the lower ice chute then take out all four allen head cap screws and pull the breaker off the auger and evaporator. If the bearing only needs grease, inject grease into the bearing using Scotsman grease needle pn 02-3559-01 and Scotsman bearing grease cartridge, pn A36808-001. Be sure to inject grease evenly and thoroughly. See Removal and Replacement section to replace bearing or seals.



Reverse to reassemble.

NME1254 & FME1504

AUGER MAINTENANCE

	⚠ WARNING
	Hazardous Moving Parts. Rotating auger can cause personal injury. Disconnect electrical power before beginning maintenance.

In some areas, the water supply to the Ice Machine will contain a high concentration of minerals, and that will result in an evaporator and auger becoming coated with mineral scale, requiring a more frequent removal than twice per year. If in doubt about the condition of the evaporator and auger, remove the auger so the parts can be inspected.

Note: Water filters can filter out suspended solids, but not dissolved solids. "Soft" water may not be the complete answer. Check with a water treatment specialist regarding water treatment.

For more information on removal of these parts, see REMOVAL AND REPLACEMENT.

Turn off the water supply.

1. To remove the auger, remove the front and top panels.
2. Push back bail clamp holding ice chute cover to ice chute, and remove cover.
3. Unscrew and remove ice sweep.
4. Remove ice chute from evaporator.
5. Remove 4 allen screws holding breaker to evaporator.
6. Drain the evaporator by lowering and uncapping the evaporator drain hose.
7. Pull up to remove auger.

After the auger has been removed, allow the auger to dry: if the auger is not bright and shiny, it must be cleaned.

Clean the auger and evaporator as required. **DO NOT HONE THE EVAPORATOR.**

8. Replace the water seal.
9. Reverse to reassemble.

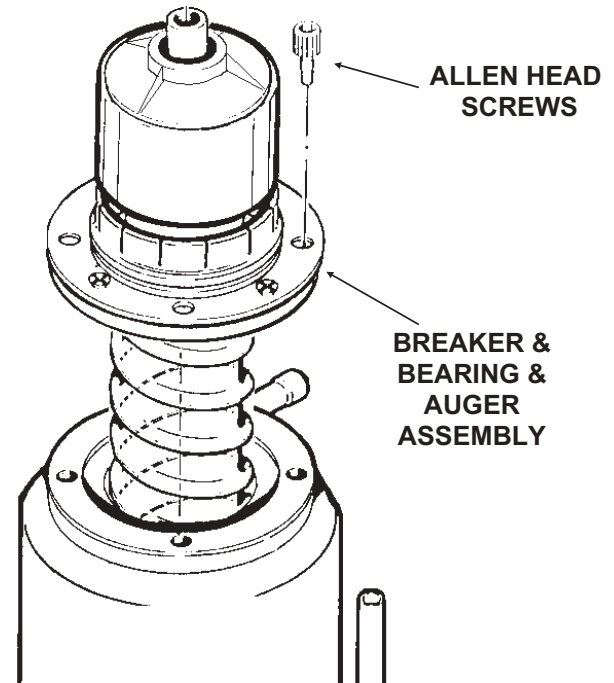

Handle auger with care, it has sharp edges.

SERVICE DIAGNOSIS:

Symptom	Possible Cause	Probable Correction	
No ice is made, nothing operates	Unit off due to no power	Restore Power	
	Unit off due to master switch in OFF position.	Switch master switch to ON.	
	Unit off due to low water level.	Check water supply, filter, strainer, float valve. Correct water supply.	
	Unit off due to ice level sensors (photo-electric eyes) blocked.	Check/clean ice level sensors.	
	Unit off due to scale on water level sensor.	Clean water level sensor.	
	Unit off due to high pressure control open.	Check for water interruption (water cooled) or fan motor failure (air cooled).	
	Auger motor hums but does not turn.	Auger can't turn. Circuit board has not yet shut unit down.	
	Unit is shut down	Circuit board has shut ice machine down due to high auger motor amp draw. Check for cause of high amp draw, including bearings, gearmotor condition and scale on auger and in evaporator.	
	Low pressure control open		Auger not turning due to: motor failure; auger relay failure on circuit board; or gears stripped. Check drive train.
			TXV restricted or not metering. Check bulb temperature.
			Lack of refrigerant. Check for leak.
	No power to circuit board.		Check harness
			Low or high pressure cut outs open
	Circuit Board gear motor relay will not close		Check, replace board
Water level or ice level sensor failed.		Check, replace sensor	
No ice, auger motor is turning	Compressor contactor coil is open	Check/replace contactor	
	Compressor will not start	Check start capacitor.	
		Check start relay	
		Check compressor windings	
Circuit board compressor relay will not close.		Check, replace board	

NME1254 & FME1504

SERVICE DIAGNOSIS

Symptom	Possible Cause	Probable Correction
Water Leak	Drain plugged up	Clean out drain
	Tubing cracked	Replace tubing
	Condensation on drain tubing	Insulate tubing
	Hose off	Reattach hose
	Reservoir cover off	Return cover to reservoir
	Reservoir cracked	Replace reservoir
	Evaporator water seal leaks	Check base of evaporator & drip pan. If the seal leaks, shut off the water, remove the auger, replace the water seal. Check gear motor for water infiltration.
Excessive water use	Water cooled model, water regulating valve not adjusted properly.	Adjust to 245 PSIG discharge pressure
	Reservoir float valve leaks thru	Replace float valve or seat
	Water cooled model, overcharged with refrigerant	Recover and weigh refrigerant. Weigh in correct charge.
	Water cooled model, condenser coated with minerals	Acid clean water cooled condenser.
Excessive ice meltage	Bin drain clogged	Clean out bin drain.
	Improper installation of drains, they are connected.	Drains must be separate.
	Poor fit between bin door and door frame	Adjust or replace
Machine makes too much noise	Evaporator coated internally with minerals	Clean with Scotsman Ice Machine Cleaner
	Motor bearings dry	Oil or replace motor

CONTROL SYSTEM DIAGNOSTICS

The control system consists of:

- Control Board
- Water Sensor
- Ice Sensors
- High Pressure Cut Out
- Low Pressure Cut Out

If the unit is OFF, check the **control board**:

1. Is the Power OK light on? If not check power to the unit. If it has power, and the Power OK light is NOT on, check the high pressure and low pressure cut outs. If they are both closed, replace the board. If the Power OK light is ON, go to the next step.

2. Is the Water OK light on? If it is, go to the next step. If not, check the water level in the reservoir. If there is water in the reservoir, check that the water sensor is plugged in. To check the **water sensor**:

A. Unplug water sensor.

B. Pull water sensor from reservoir.

C. Place one ohmmeter lead on the sensor's plug and the other on the sensor's tip. The meter should show nearly zero resistance. If it reads infinite resistance, check the tip for corrosion. If it is clean and still reads open, replace the sensor.

OR connect a copper wire to the wire where the water sensor plugs into and place the other end in the water. The water OK light should go ON. If it does not, replace the control board.

3. **Ice sensor check.** Is the Bin Full light Off? If it is OFF and the Service light is Off, and the unit is not running, replace the control board.

If it is OFF and the auger motor is running but the compressor is not, check the compressor contactor coil.

If it is on, the ice sensors may be blocked. Remove them and check for mineral scale. Scotsman's test box can also be used to determine if the ice sensors or board are defective.

Using the tester:

A. Disconnect the ice sensors at the connection by the ice chute. Connect the LED and PHOTO TRANS wires to the control board's wires.

B. With the On - Off (mode) switch in either position, move the Bin Full switch on the tester to Bin Full - the tester's light will blink and after a few seconds the bin full light on the control board will come on. If not, replace the board.

Move the Bin switch on the tester to Bin Empty. The light on the tester will go out, and after a few seconds the Bin Full light on the board will go out. If master switch is ON, the unit should start.

4. **High pressure** cut out check.

Disconnect electrical power.

Pull the wires off the high pressure cut out.

Use an ohmmeter to determine if the switch is OPEN, If it is, check the discharge pressure. If the discharge pressure is less than 300 PSIG, replace the high pressure cut out.

If the high pressure cut out is open and the system has high discharge pressure, check for the cause.

5. **Low pressure** cut out check.

Disconnect electrical power.

Pull the wires off the low pressure cut out.

Use an ohmmeter to determine if the switch is OPEN, If it is, check the suction pressure. If the suction pressure is greater than 20 PSIG, replace the low pressure cut out.

If the low pressure cut out is open and the system has low suction pressure, check for the cause.

NME1254 & FME1504

REMOVAL AND REPLACEMENT: Water Reservoir & Bin Control

WATER RESERVOIR

1. Shut off the water supply to the ice machine.
 2. Remove front panel.
 3. Remove reservoir cover.
 4. Disconnect water inlet tube from reservoir inlet fitting.
 5. To remove float valve, push in "locking tabs" as shown and pull float up.
- Note: The plunger/seat is available separately as a part.
6. To remove reservoir, pull up and remove water sensor.
 8. Disconnect water outlet tubes.
 9. Remove mounting screws from reservoir bracket, and remove reservoir from ice machine.
 10. Reverse to reassemble.

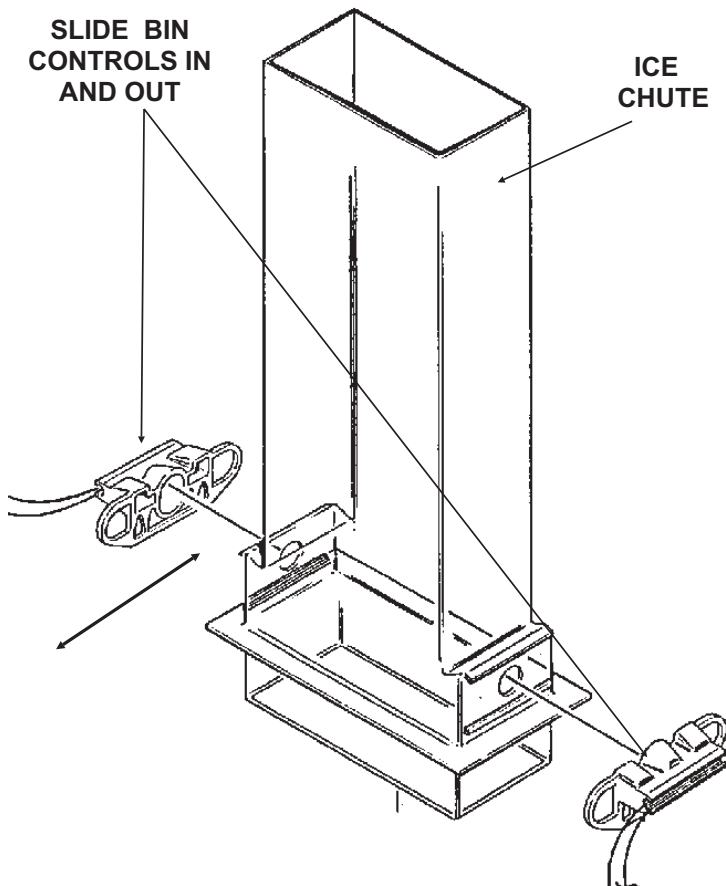
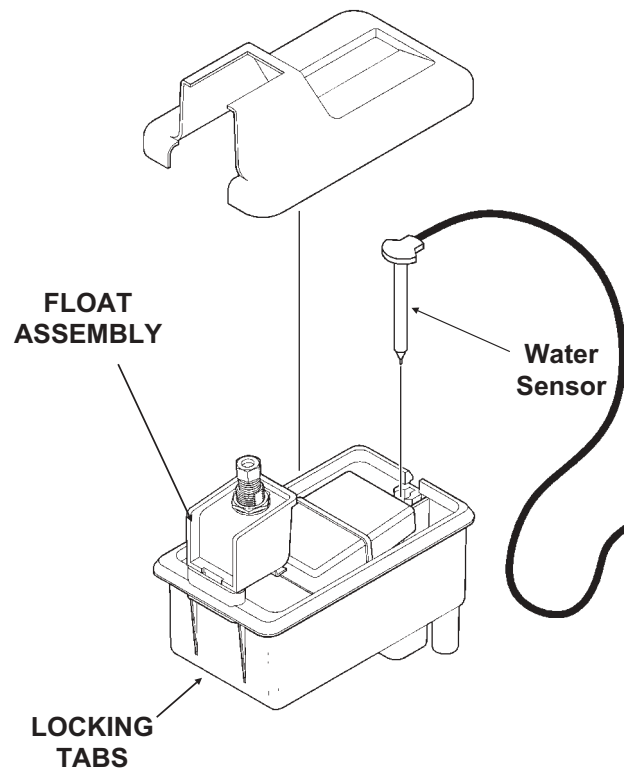

BIN CONTROLS (Ice Level Sensors)

1. Disconnect electrical power.
2. Remove front panel.
3. Remove control box cover.
4. Locate ice chute, at the base of the chute, in front of and behind it are two plastic bin control mounts.
5. Slide each bin control to the left, and in the control box, disconnect the electrical leads connecting the bin control to the circuit board.
6. Reverse to reassemble, be certain that the bin controls are aligned so that the ice level sensors are visible (centered) through the holes in the ice chute.

REMOVAL AND REPLACEMENT: Bearing And Breaker

Note: Removal of the auger, water seal, evaporator and gearmotor must begin at the top of the assembly.

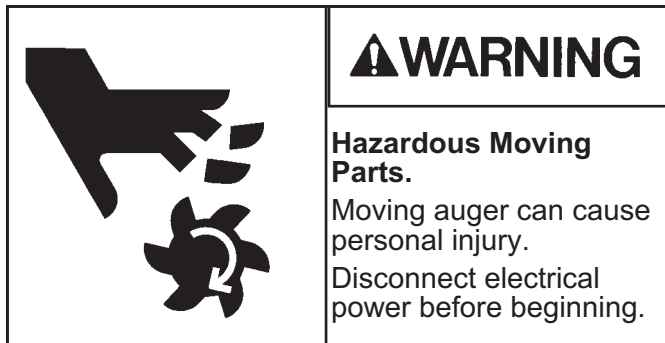

To Remove the Breaker Bearing Assembly:

1. Remove panels and disconnect electrical power.
2. Push back bail clamp and remove ice chute cover.
3. Unscrew and remove ice sweep.
4. Remove insulation halves from outside of ice chute, lift up and remove ice chute.
5. The breaker may be removed from the auger and evaporator without disturbing the auger.
 - a. Unscrew breaker cover from breaker (left hand threads)
 - b. Unscrew auger stud from top of auger.
 - c. Unscrew 4 allen head cap screws holding breaker to evaporator.

d. Lift up, and remove breaker/bearing assembly from auger & evaporator.

6. Service the bearing. Check for rust, rough spots and damage.

a. The bearing is pressed into the breaker, to remove the bearing and replace it an arbor press is needed.

b. Replace lower seals before installing new bearing in breaker.

Note: seals must be pressed in with a tool pushing against the outer edge only, they will not install by hand.

Replace parts as required. Re-grease bearing with Scotsman part no. A36808-001 bearing grease.

Replace top seal, and check the o-rings, replace if cut or torn.

7. Reverse to reassemble: specific tools and materials are required to install properly.

a. Add food grade grease such as Scotsman part number 19-0569-01 to the seal area before installing on the auger.

b. Check the seal to shaft areas for cuts, or rough spots: none are permitted.

Note: Flaker parts are illustrated, nugget parts are similar.

Step 5-a

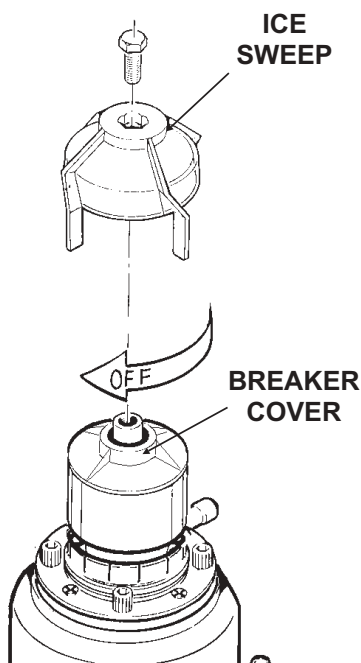

Step 5-b

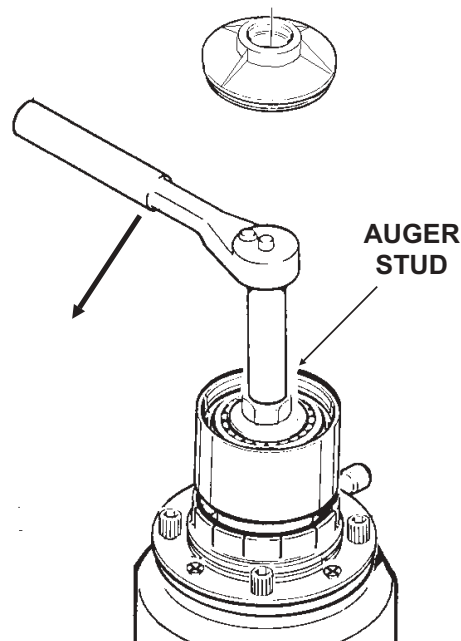

Step 5-c

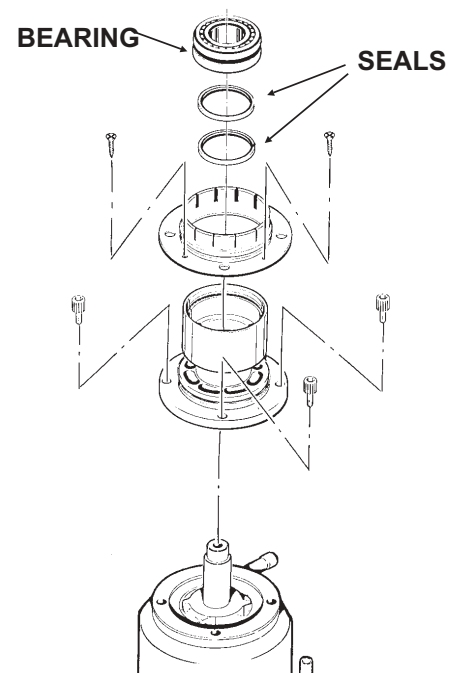

NME1254 & FME1504

REMOVAL AND REPLACEMENT: Auger

To Remove the Auger:

Turn off the water to the machine, and unclip the evaporator drain hose, pull it down and drain the evaporator into the bin or a container.

1. The top panel must be removed.

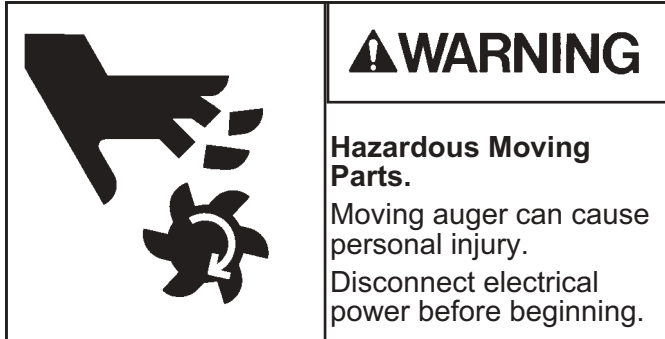

2. Push bail clamp off of ice chute cover, remove ice chute cover.

3. Unscrew ice sweep.

4. Remove ice chute body.

Inspect the auger, the critical areas of the auger are:

1. The auger body. It should be clean and shining. Sometimes an auger will appear clean when wet, but after it is dry it will be seen to be stained. Scrub the auger with ice machine cleaner and hot water.

Ice machine cleaner is an acid. Handle it with extreme care, keep out of the reach of children.

2. The water seal area. Because the auger has been removed, the water seal will have to be replaced. Remove the water seal top half from the auger, and inspect the auger for minerals clean as required.

BREAKER AND AUGER ASSEMBLY

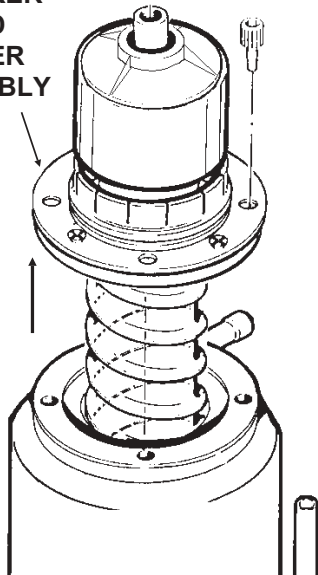

5. The auger and breaker/bearing may now be removed as an assembly.

a. Unscrew 4 allen head cap screws holding breaker to evaporator.

b. Lift up on breaker and remove auger from evaporator.

Note: If the auger is stuck, the breaker

must be removed from the auger.

The breaker may be removed from the auger and evaporator without disturbing the auger.

a. Unscrew breaker cover from breaker (left hand threads)

b. Unscrew auger stud from top of auger.

c. Unscrew 4 allen head cap screws holding breaker to evaporator.

d. Lift up and remove breaker from evaporator.

e. If the auger is stuck use a slide hammer type puller to pull on the auger at the threaded hole.

The size of that hole is 5/8"-18.

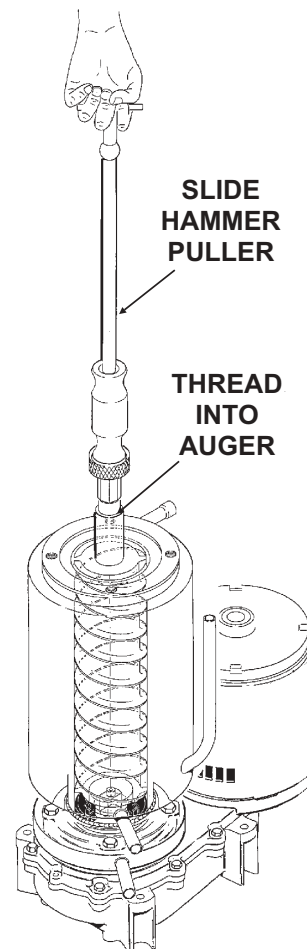

REMOVAL AND REPLACEMENT: Water Seal

REMOVAL OF THE WATER SEAL

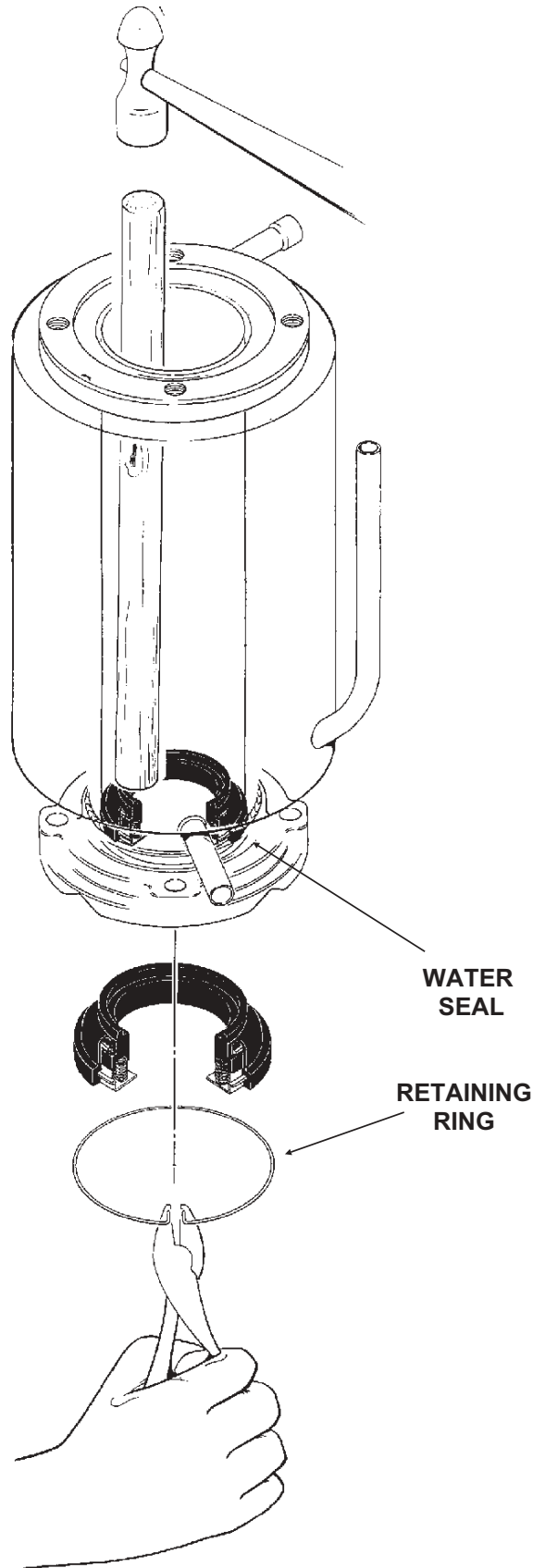

To Remove the Water Seal:

(Assuming all steps to remove the auger have been performed.)

1. The gearmotor/evaporator assembly will have to be exposed.
2. Remove the 4 hex head cap screws holding the evaporator to the gearmotor assembly. Lift the evaporator up and off of the gearmotor.
3. Remove the snap ring or wire retainer from the groove under the water seal.
4. Pull or drive out the lower half of the water seal.

To Replace the Water Seal:

1. Lubricate the water seal with water, and push the water seal into the bottom of the evaporator slightly past the groove for the snap ring.
2. Replace the snap ring and pull the water seal down against it.
3. The part of the water seal that rotates with the auger must also be replaced. Remove the old part from the auger and clean the mounting area.
4. Place a small bead of food grade silastic sealant (such as 732 RTV or Scotsman part number 19-0529-01) on the area of the auger where the water seal is to be mounted.
5. Carefully push the water seal (rubber side against the auger shoulder and the silastic.)

Do not get any silastic onto the face of the seal.

6. Allow the auger and seal to air dry until the silastic is dry on the surface.
7. If the original water seal was leaking, it would be a good idea to inspect the interior of the gearmotor.

NME1254 & FME1504

REMOVAL AND REPLACEMENT: Evaporator

REPLACING THE WATER SEAL

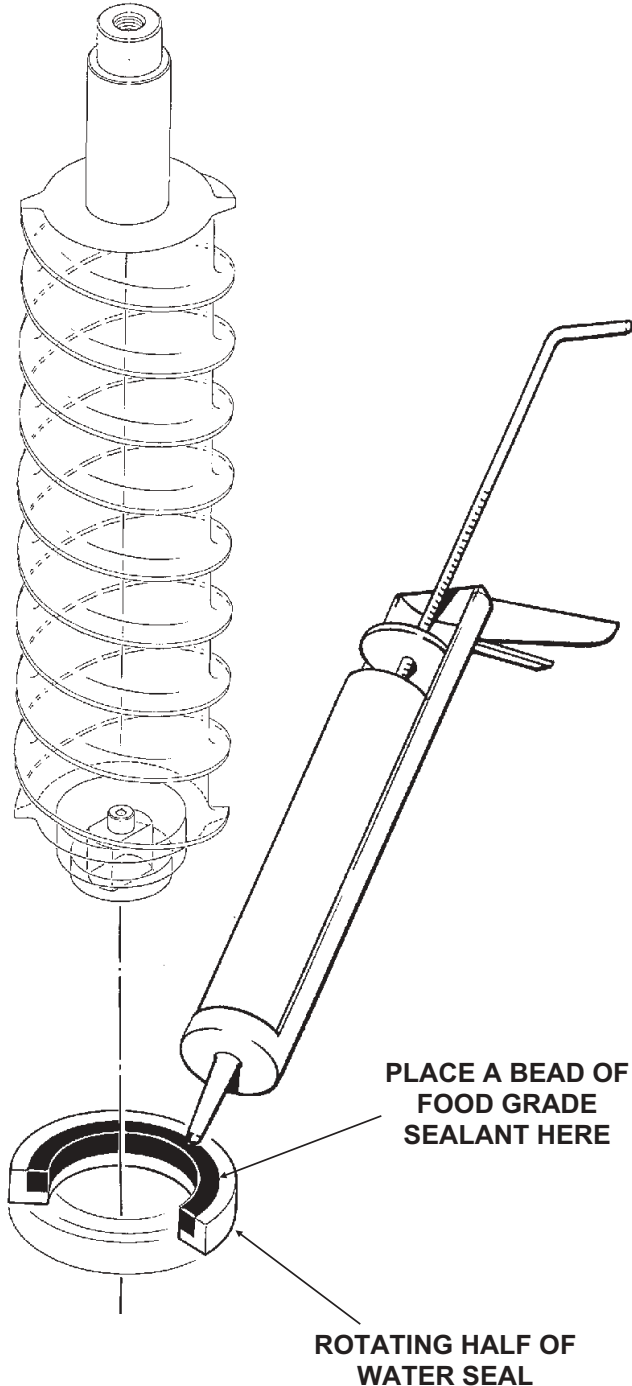

To Replace the Evaporator:

(Assuming all the steps for removal of the thrust bearing, breaker, auger, and water seal have been performed.)

1. Recover the refrigerant from the ice machine.
2. Unsweat the refrigerant connections:
 - a) At the thermostatic expansion valve outlet.

Heat sink the TXV body when unsweating or resweating the adjacent tubing.

- b) At the suction line at the joint about 3" from the evaporator.
3. Remove the evaporator.
4. Unsweat the drier from the liquid line.
5. After installing a new water seal in the new evaporator (see "To Replace the Water Seal") sweat in the new evaporator at the old connections.
6. Install an new drier in the liquid line.
7. Evacuate the system until dehydrated, then weigh in the nameplate charge. Check for leaks.
8. Install auger, breaker, breaker bearing assembly, and ice discharge chute in reverse order of disassembly. See "To Reassemble Evaporator and Auger"

To Reassemble the Evaporator and Auger

1. After the gearmotor has been inspected, fasten the evaporator to the gear motor, be sure that the number of shims indicated on the gear case cover is in place between the gearcase cover and the drip pan gasket. Torque the bolts to 110 inch pounds.
2. Lower the auger into the evaporator barrel, slightly turning it to match up with the drive end. **Do Not Drop the Auger Into the Evaporator.**
3. Complete the reassembly by reversing the disassembly for the breaker & thrust bearing assembly.

REMOVAL AND REPLACEMENT: Gearmotor



⚠ WARNING

Electrical Shock Hazard.

Electrical power can cause personal injury. Disconnect electrical power before beginning.

To Check the Motor:

1. Remove wires from terminals 1 and 2.
2. Use an ohmmeter to check for continuity. If there is none, replace the motor only. If there is continuity, but the motor will not start, check the motor's start switch.
3. Remove motor end bell or motor stator. With ohmmeter wires attached to 1 and 2 move centrifugal switch actuator up and down to simulate motor speed. If the ohmmeter does not show any change or shows an open circuit, replace the switch or motor.

To Remove and Repair the Gearmotor Assembly:

(Assuming that the procedures through removal of the water seal have been performed.)

1. Remove the electrical wires from the gear drive motor.
2. Unscrew the 4 cap screws holding the gearmotor to the gearmotor plate.
3. Remove the gearmotor from the icemaker.

To Inspect the gearmotor.

A) Remove the cap screws holding the gearmotor case halves together and pry the two cases apart.

B) Remove the cover: lift up until you can feel internal contact, then pull the cover towards the output gear end, and then lift the cover (with drive motor attached) up and away from the gear motor case.

Note: The case cover output gear, bearings, and shaft are one pressed together assembly. Replace as a unit.

C) Inspect the oil, gears, and bearings. If the oil level and condition is acceptable, quickly

check the gears and bearings. They are likely to be fine if the oil appears normal.

If there is evidence of water in the oil (rusty bearings and gears; the oil having a creamy white appearance; oil level too high) carefully inspect the bearings and gears. If in doubt about the condition of a part, replace it. The oil quantity is 14 fluid ounces, do not overfill.

Note: The gears and bearings are available only as pressed together sets.

D) After replacing parts as required, (if any) reassemble the gearcase. The two smaller gears and the oil should be in the lower case, the output gear will be with the cover. As you lower the cover onto the lower case, cover will have to be moved closer to the second gear after the output gear has cleared the second gear top bearing.

E) After the case is together, and the locating pins are secure in both ends, replace all cap screws.

4. Bench test the gearmotor, check for oil leaks, noise, and amp draw.

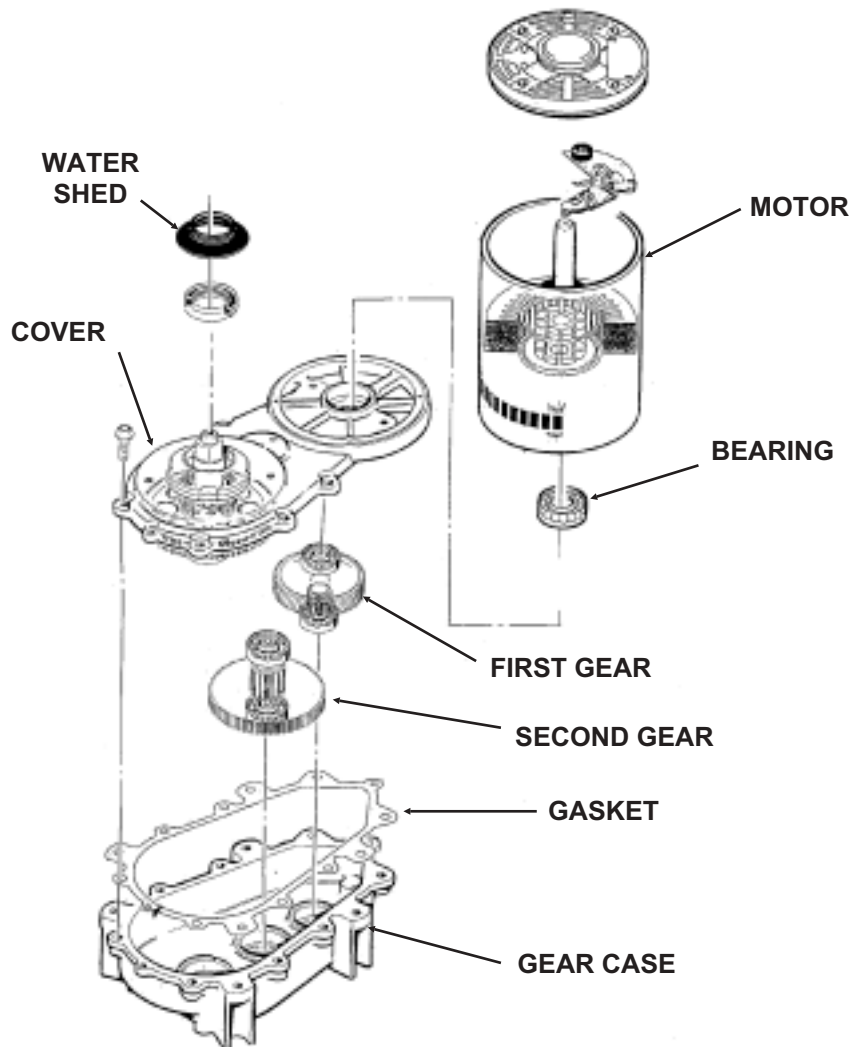

NME1254 & FME1504

Refrigeration System Service

General: This ice machine uses R-404A refrigerant and polyolester oil. Do NOT use mineral oil in this refrigeration system.

- When the system is serviced, a special liquid line drier is required. It is included with replacement compressors.
- R-404A is not compatible with mineral oil so these ice machines use Polyolester oil. Polyolester oil absorbs water very easily. A system opened for service must be re-sealed as soon as possible (15 minutes maximum).
- Special leak detection equipment is required to locate small refrigerant leaks. Usually a leak detector capable of detecting a Halogenated refrigerant or HFC-134a will work. Check with the leak detector manufacturer if in doubt.
- Evacuate to 300 microns.
- Liquid charge the system

Access Valves: To use the access valves:

- Remove the cap from the stem, use a 3/16" allen wrench to check that the valve is CLOSED. The remove the core cap.
- Close the valve and replace the caps when done. The valve must be closed and the caps must be on or the valve will leak.

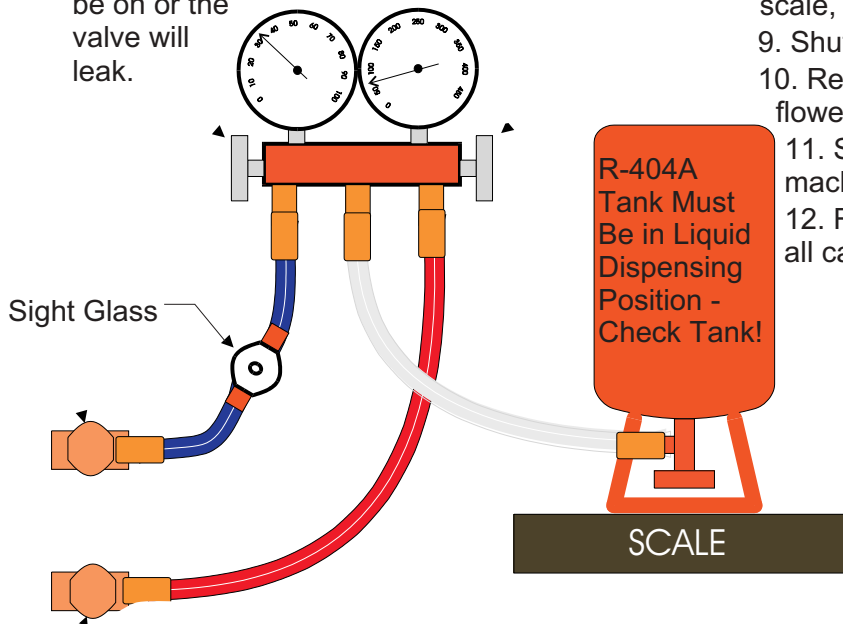
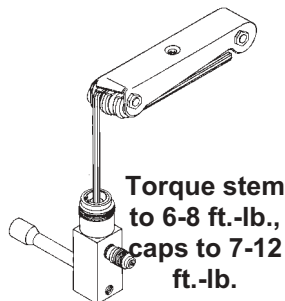

Hose Connection Schematic for Liquid Charging

Instructions for Liquid Charging R-404A

In preparation for charging, the low side hose should have a sight glass, and/or a restricting device (such as a "Charge Faster") installed in it for metering liquid into the low side of the system.

1. After a thorough evacuation shut off the manifold valves and switch off the vacuum pump.
2. Place a drum of R-404A onto an electronic scale.
3. Attach the charging hose to the drum.
4. Open the valve on the drum and purge the charging hose.
5. Zero out the scale.
6. Shut the low side access valve at the ice machine.
7. Open the discharge manifold valve full open.
8. Watch the scale, when the correct charge is shown, shut the manifold valve.

Note: If all of the charge will not "go in" the discharge side:

- A. Shut the discharge access valve at the ice machine.
 - B. Switch the machine on.
 - C. Open the low side access valve at the ice machine.
 - D. Open the low side manifold valve and observe the sight glass to be certain that only gas is flowing into the system.
 - E. When the proper charge is indicated on the scale, shut off the manifold valve(s).
9. Shut off the valve on the refrigerant drum.
 10. Re-open the manifold valves until all liquid has flowed out of the hoses.
 11. Shut the low side access valve on the ice machine.
 12. Remove hoses from ice machine and replace all caps.

What to Do Before Calling for Service

If the machine is off, not making ice:

1. Check the water supply to the ice machine. The machine is designed to shut off if there is no water to it. Check the filters if there are any.
 2. Check the power supply to the machine. Reset the breaker if it is tripped.
 3. If both water and power have been checked and are available, try switching the power Off and then On. After 2 minutes the machine should restart.
- If this procedure restarts the machine, service should be called the next time the machine stops.